

LEADER 
ELEVATION
www.leader-elevation.fr



Hydro-Park 2525

Eco Parking Stackers 3 Floors

Please notice that all the specification and technical details quoted within this catalog/datasheet/installation manual maybe out of date or have minor differences with our standard equipment from time to time.

Our company reserve the right to change technical details in the description, information and illustrations in this documentation.

All the specification and technical details will be subjected to the drawing confirmed by the sales contract.



> Introduction

Hydro-Park 2525 is a Leader Elevation newly developed 3-floor version of HP2236 and can be used as a 3-floor stacker parking like eco version of HP3130. The design of HP2525 is based on the HP2236, the equipment is used as valet parking or storage. The platforms move only vertically driven by a hidden strong hydraulic cylinder with wire ropes.

Features:

- Commercial grade
- Overlap platform design
- Ramps total height 150mm
- Ground floor unlimited, 2nd floor 2500kg and 3rd floor 2000kg capacity
- Entrance width 2492mm, 2nd floor 2100mm and 3rd floor 2200mm driven width
- Clear height 2100mm on each floor
- 4000mm/min (no-load) traveling speed
- 3.0kw hydraulic pump
- Powder coating finishing
- Dynamic anti-fall lock
- Dust/oil dripping cover
- Lock release failure detection
- Semi-auto lock release
- Emergency stop button
- Up & down key switch
- Self-standing & supporting structure (Optional)
- TUV Rheinland Certified

General Parts

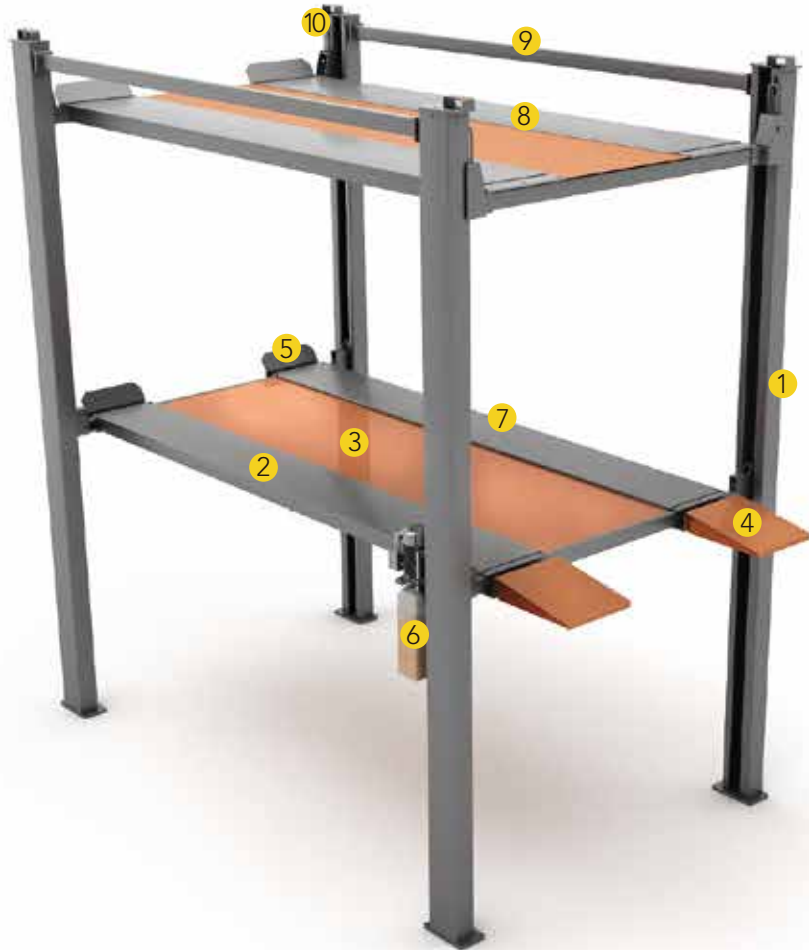

- 1 Post
- 2 Carry board
- 3 Dust/oil dripping tray
- 4 Ramp
- 5 Wheel stopper
- 6 Power pump
- 7 Lower platform
- 8 Upper platform
- 9 Side beam
- 10 Electric hanger

Advantages

Super cost-effective

Less than half cost of the HP3130

Maximize usage of the building height

3 car height (customization may require)+
135mm+ 120mm+ 3 x safety clearance (check
local authority)

Super-wide usable width

Entrance width 2492mm, 2nd floor 2100mm and
3rd floor 2200mm driven width

Super-fast traveling speed

4000mm/min traveling speed without load, 10 sec
slower with load

Hydro-Park
2525

Full size dynamic lock

The platforms are traveling up and down with
full size dynamic lock

Dust/oil dripping tray

Each platform has a dust/oil dripping tray to
make sure the cars will not be polluted

Low usage cost

Gravity lower down save energy

Easy installation

Simple structure, major parts are pre-assembled

Professional packaging and delivery

20ft container load 6 units, 40ft container load
12 units

> General

Model Number	Hydro-Park 2525
Lifting capacity	Ground floor unlimited, 2nd floor 2500kg and 3rd floor 2000kg
Gross weight	2000kg
Useable height	Ground floor & second floor 2100mm
Equipment height	4966mm
Usable width	2492mm
Total width	2802mm
Total length	5060mm
Total Rump height	150mm
Locking device	Dynamic
Pump motor	3kw
Power required	220-420V, single or 3 phase, 50/60Hz
Control voltage	24v
Operation model	Key Switch
Lifting speed	4000mm/min (no-load)
Surface treatment	Powder coating
Lock release	Semi-auto

Safety devices

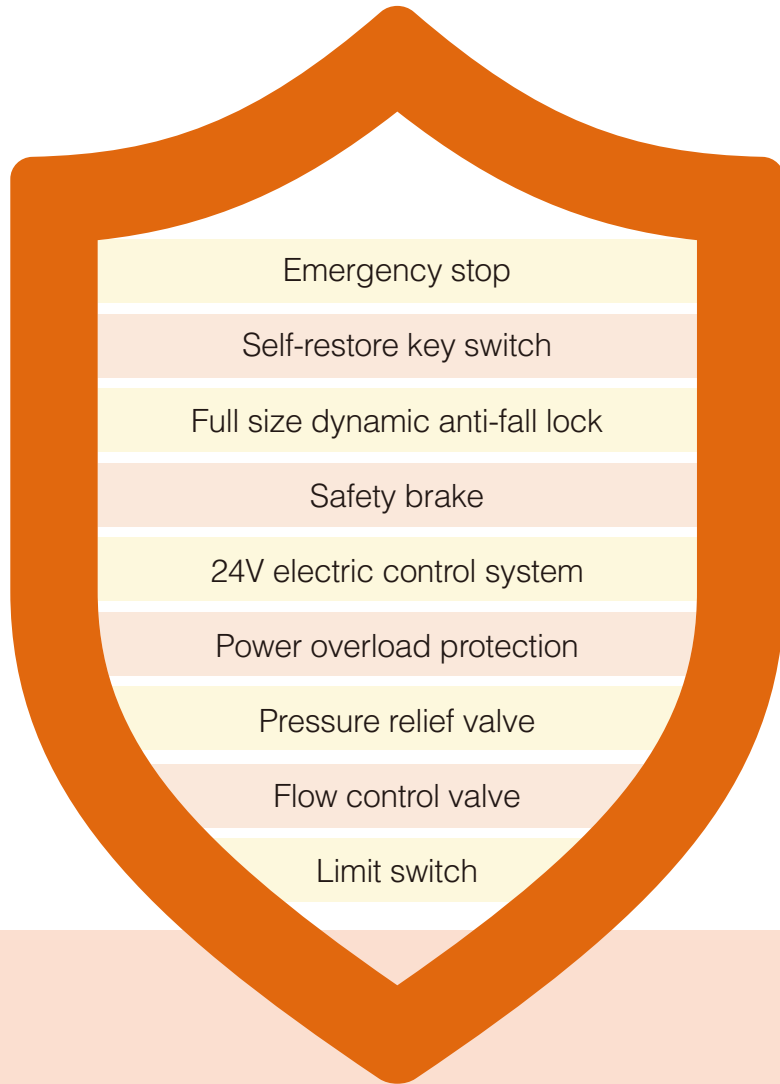

Dimensions

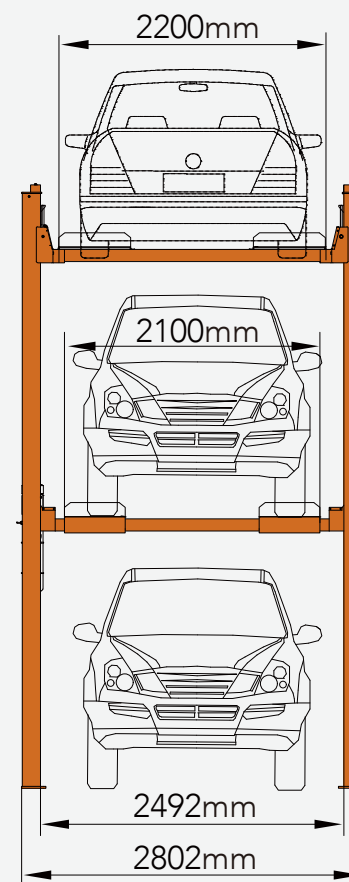
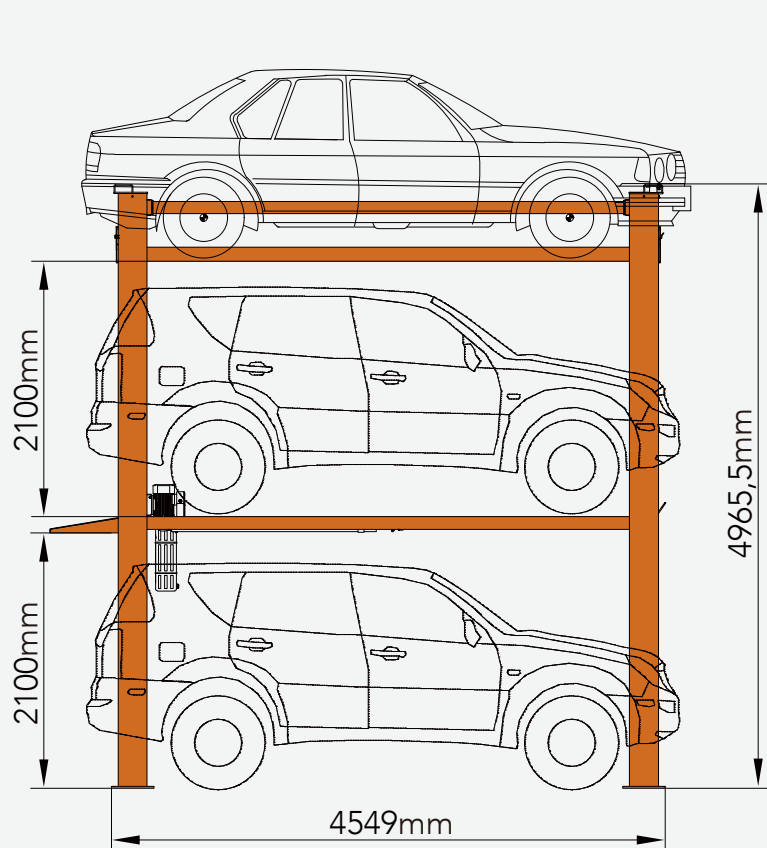

> Packaging & Container load

Container size	Loading quantity	Net weight
20ft	6 units	12t
40ft	12 units	24t

How many cars can be parked on each unit, any requirement?

3 cars, the car parked on the ground floor has no limit on the weight capacity and has 2100mm clear height, the car parked on the 2nd floor has a weight limit of 2500kg and has 2100mm clear height, the car parked on the stop floor has a weight limit of 2000kg and no limit of the clear height but the ceiling.

How do I calculate the floor height required by using HP2525?

The formula is as follow:
 $2100\text{mm} + 135\text{mm} + 2100\text{mm} + 120\text{mm} + \text{height of the 3rd car} + \text{safety clearance}$ (check local authority), to customize the height of each floor, please consult our sales people.

How to operate the HP2525?

The top platform will sit on the lower platform on the ground floor, after park the first car on the top platform, lift up the top platform with the car all the way to the top level, lock the top platform, lower down the lower platform to the ground and then park the 2nd car on the lower platform, lift the lower platform and park the 3rd car

on the ground floor.
Drive away the ground floor car and lower down the lower platform and then drive away the car on the lower platform, lift up the lower platform all the way to the top to take the top platform off the lock, take the top platform all the way down to the ground floor and drive away the top floor car.

What's the supply voltage?

Standard voltage is 220v, 50/60Hz, 1Phase. Other voltages could be customized according to clients' request.

Could HP2525 used outdoor?

The HP2525 does have an outdoor version, for more information, please consult our sales people.

Warranty

Hydro-Park 2525 has a 5 years warranty on structure and 1 year on whole machine. Within the warranty period, power units, hydraulic cylinders, and all other assembly components such as slip plates, cables, chains, valves, switches etc, are warranted for 1 year against defects in material or workmanship under normal use. Leader Elevation shall repair or replace at their option for the warranty period those parts returned to the factory freight prepaid which prove upon inspection to be defective. Leader Elevation will not be responsible on any labor costs unless pre-agreed. Leader Elevation will not responsible for the modification or upgrade of the product from the client unless pre-agreed.

These warranties do not extend to...

- defects caused by ordinary wear, abuse, misuse, shipping damage, un-proper installation, voltage or lack of required maintenance;
- damages resulting from purchaser's neglect or failure to operate products in accordance with instructions provided in the owner's manual(s) and/or other accompanying instructions supplied;
- normal wear items or service normally required to maintain the product in a safe operating condition;
- any component damaged in shipment;
- other items not listed but may be considered general wear parts;
- damage caused by rain, excessive humidity, corrosive environments or other contaminants.
- any change or modification made to the equipment without pre-agreed.

These warranties do not extend to any cosmetic defect not interfering with equipment functionality or any incidental, indirect, or consequential loss, damage, or expense that may result from any defect, failure, or malfunction of a Leader Elevation product or the breach or delay in performance of the warranty.

This warranty is exclusive and in lieu of all other warranties expressed or implied.

Leader Elevation reserves the right to make design changes or add improvements to its product line without incurring any obligation to make such changes on product sold previously.

Warranty adjustments within the above stated policies are based on the model and serial number of the equipment. This data must be furnished with all warranty claims.

■ About the customized size

If the size of the platform or height of the clearance need to be customized based on customer require, dif culties might arise when entering or exiting the cars on the parking units. This depends on car type, the access and the individual driving behavior.

■ Operating device

The position of the operating device depends on the project (switch post, house wall). From bottom of the shaft to the operating device an empty pipe DN40 with taut wire is necessary.

■ Temperature

The installation is designed to operate between +5 ° and +40 ° C. Atmospheric Humidity: 50% at +40 ° C. If the lol circumstances differ from the above please contact Leader Elevation.

■ Illumination

Illumination has to be considered acc. to local requirements by client. Illumination in the shaft for maintenance is required to be minimum 80 Lux.

■ Maintenance

Regular maintenance by quali ed personnel can be provided by means of an Annual Service Contract.

■ Protection against corrosion

Independent of a maintenance workings has to be carried out acc. to Leader Elevation Cleaning and Maintenance Instruction regularly. Clean up galvanized parts and platforms of dirt and road salt as well as other pollution (corrosion danger)!